



Integration Of Innovation

- Forging
- Machining
- Casting

Kirtan Precision With by high
Technology innovation..!



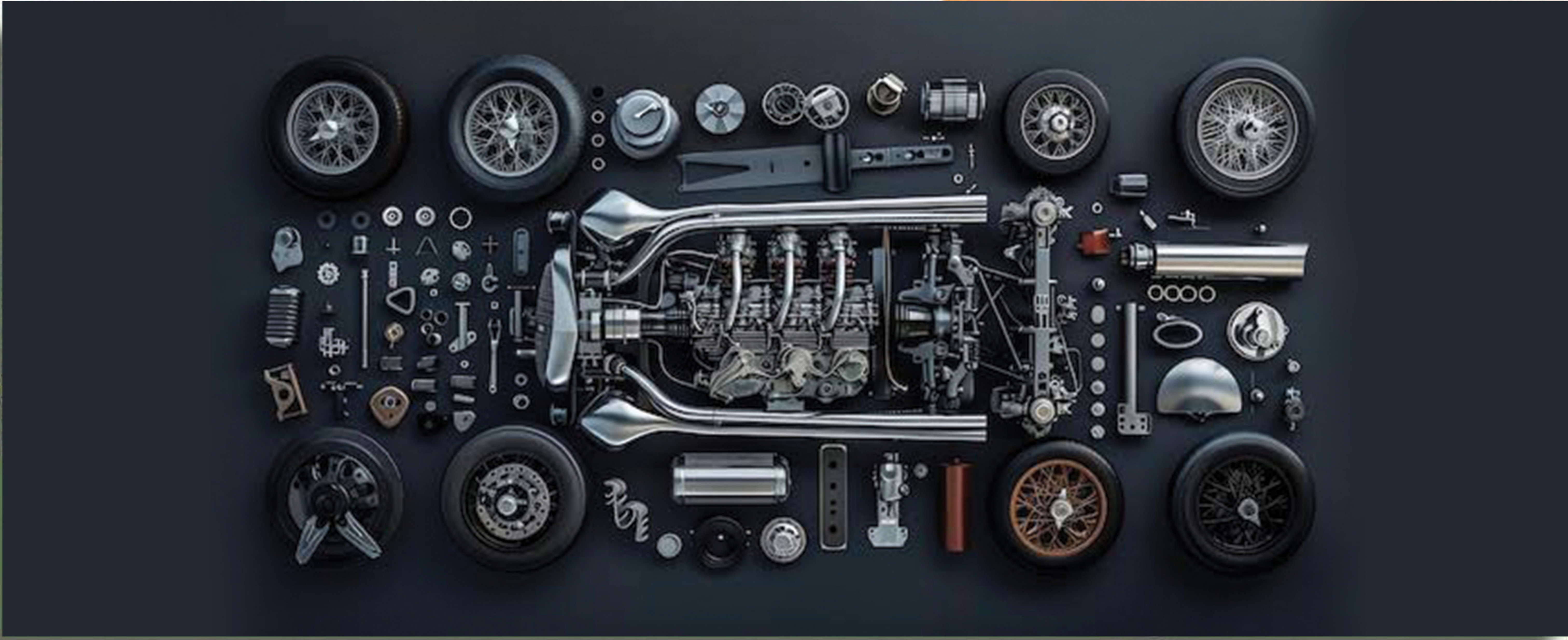

- ⇒ **Kirtan Precision** manufactures quality **FORGING & CASTING** products for farm equipment, automotive and heavy industries. Spread across a sprawling area of 2,000 sq m, our state-of-the-art manufacturing facility coupled with cutting-edge technical expertise offers quality products and cost-effective solutions that match global standards as well as customer requirements.
- ⇒ **Kirtan Precision** is an amalgamation of two positive indicators of success- Synergy and Innovation.

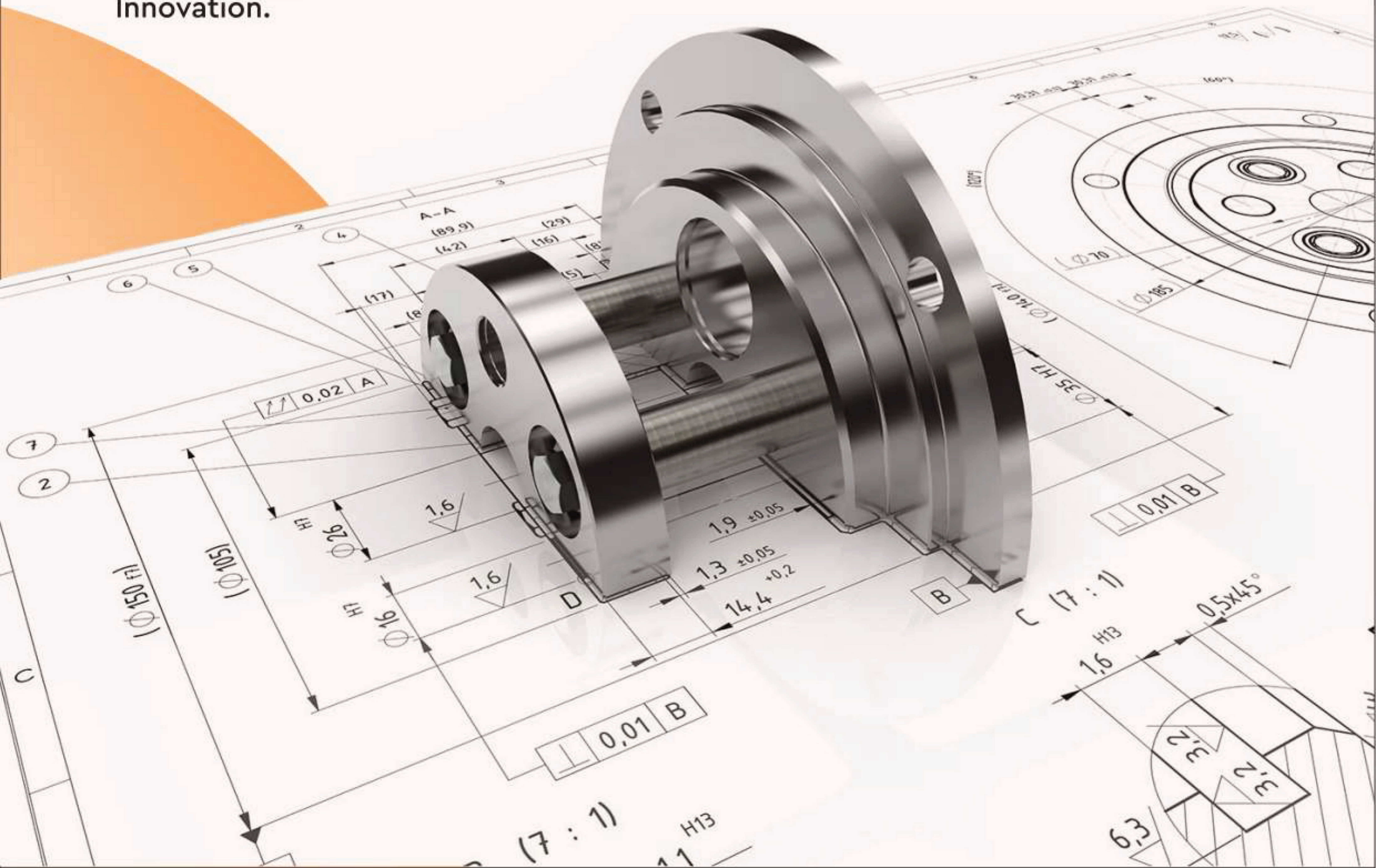

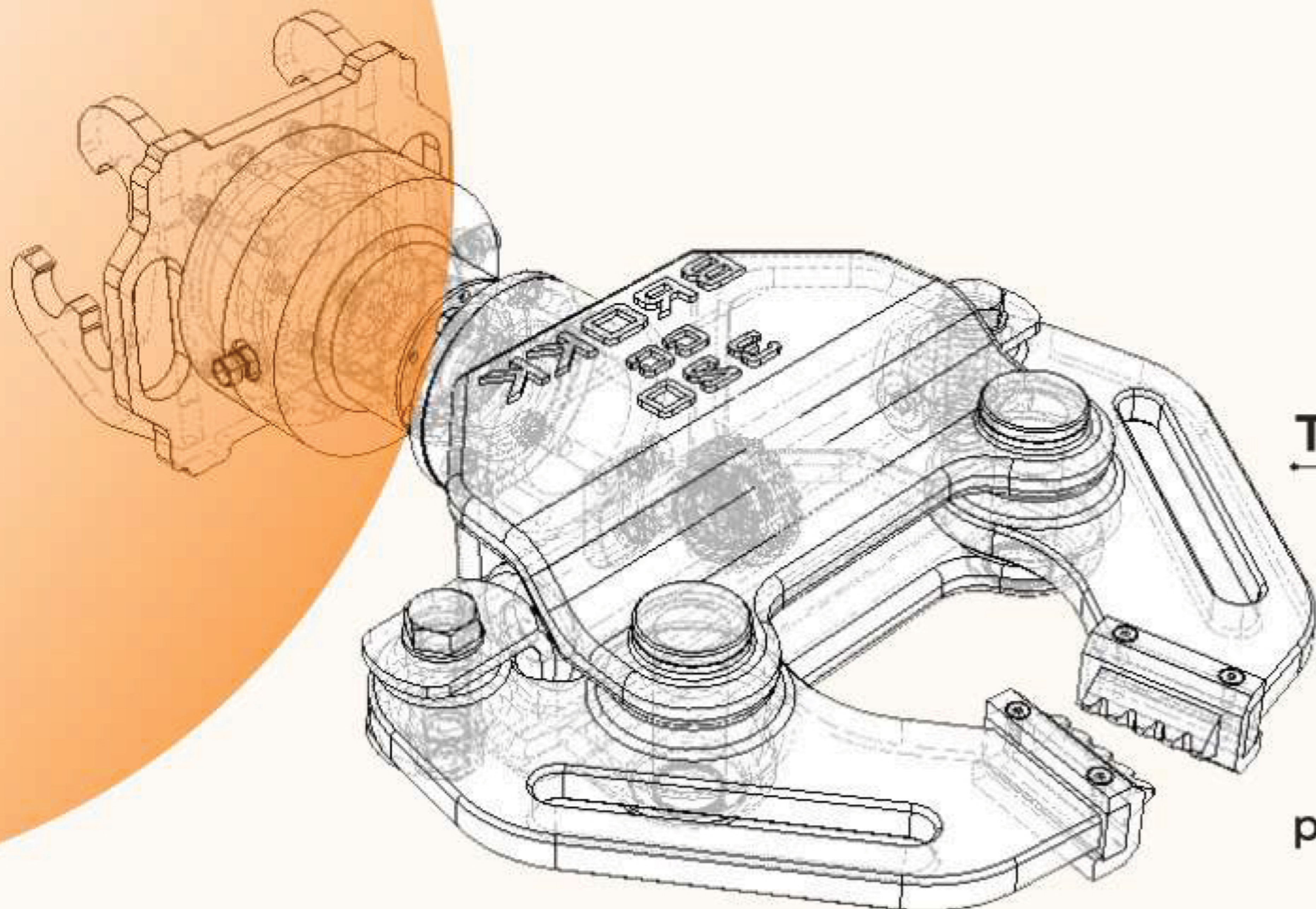

To deliver excellence, we believe in,

FOCUS ON INNOVATION

A part OF KP DNA, We strive to fuel newer insights and technologies to continuously improve plant performance and product excellence.

➤ GROWTH FOOTPRINT

Powered by quality and productivity. KP sales are well-poised to increase from approximately INR 6 crore to INR 100 crore in the next five years.

This will entail an investment of nearly 10 crore in the same period, 86% of which will be mainly for plant and machinery.

➤ TRUST ON QUALITY

At KP our people are quality conscious and processes are quality Certified.

➤ TRUST IN TEAM POWER

We are leveraging the knowledge pool of best in trade talent from varied fields with the aim to provide benchmark forging & casting solutions across industries and geographies.

➤ At Kirtan Precision you get,

- ◆ All type of forging and casting designs for any industry.
- ◆ Advanced technical expertise.
- ◆ High-quality products and services.
- ◆ World class infrastructure.
- ◆ Customized cost effective solutions.

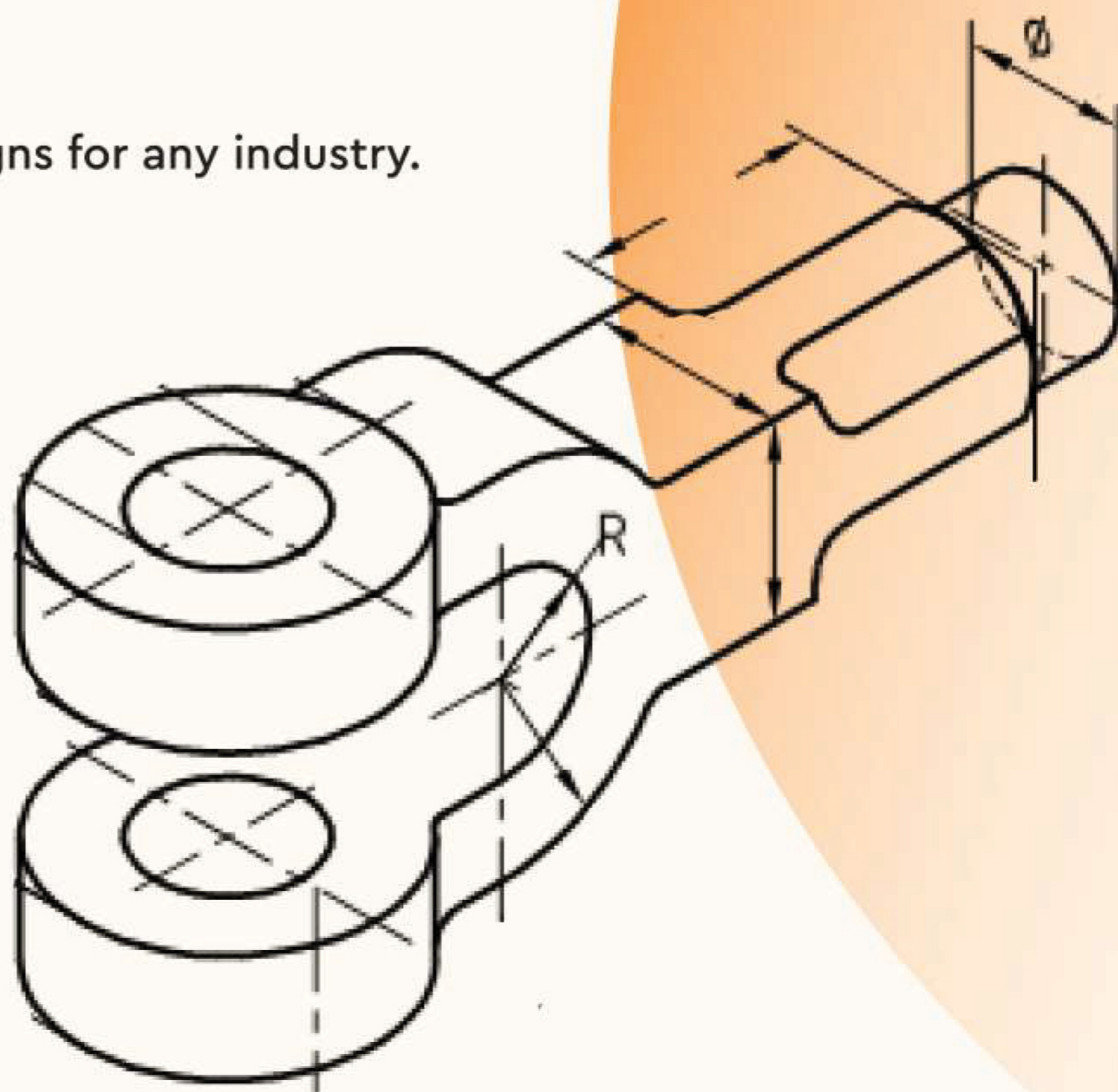
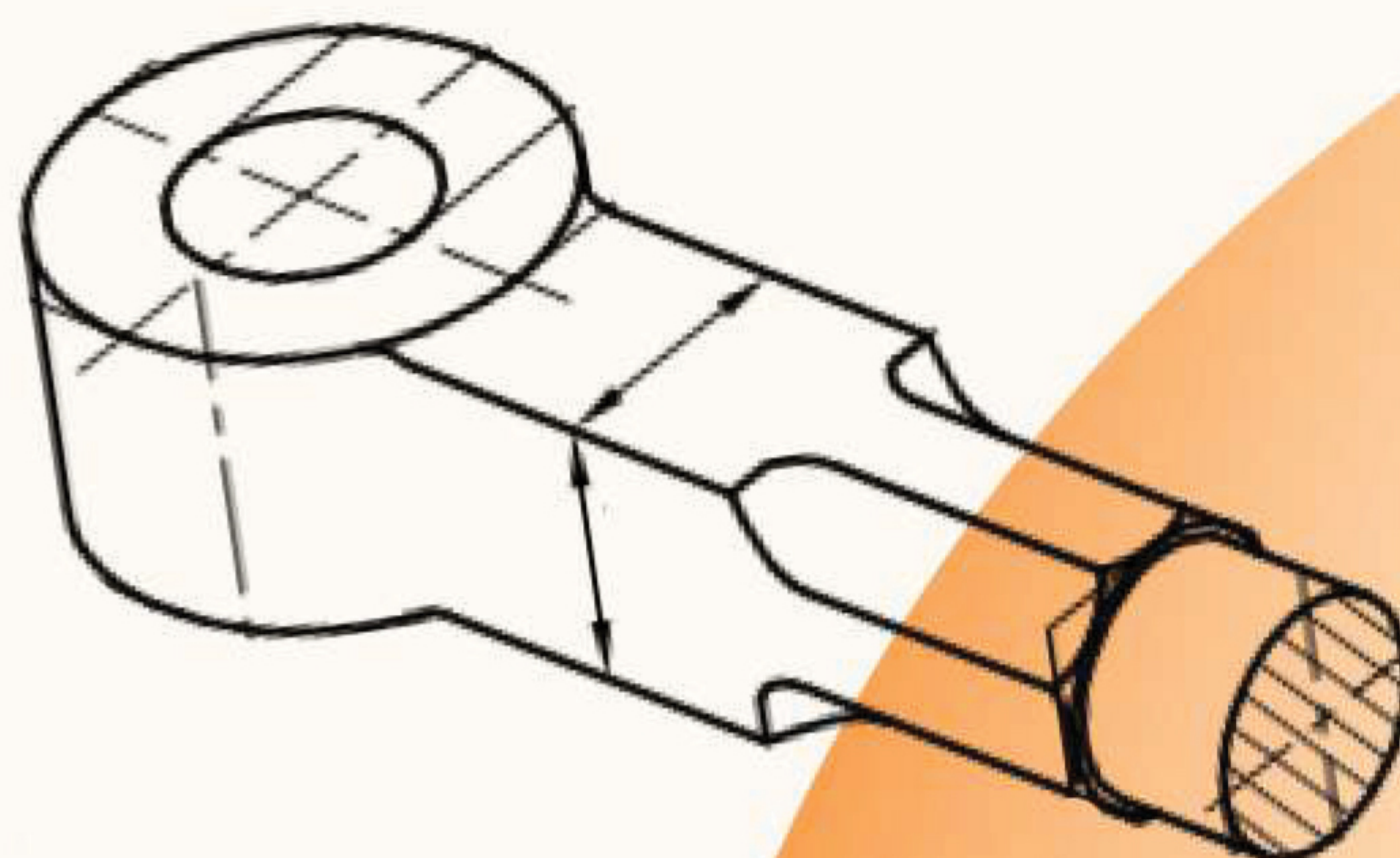

▷ Products:

Innovation and customization is at the heart of every product and service we deliver. A rich repertoire of experience, best technology and skill sets enable us at Kirtan Precision to offer you, products and services as per your specific requirement, without compromising on quality, and at the same time, being kind to your budget. Be it any forging and casting design for any industry, we at Kirtan Precision deliver the best at the right time.

⇒ OUR PRODUCTS AND SERVICES INCLUDE



Automotive



Railway



Upset Forging



Pipe Fittings



Oil & Gas



Defense



Power Transmission



CNC Machined

⇒ KP ADVANTAGES

- ↳ COST EFFICIENCY
- ↳ TIMELY DELIVERY
- ↳ IMPECCABLE SERVICE
- ↳ READY TO USE PRODUCTS
- ↳ IN DEPTH UNDERSTANDING OF OPERATIONS
- ↳ VALUE ENGINEERING AND VALUE ANALYSIS
- ↳ CUSTOMISATION CAPABILITIES



THE KIRTAN PRECISION EDGE...!

- ➡ From Design To Delivery, Quality Enhancement To Cost Reduction We Bring Together Energized Talent And Cutting-Edge Technology To Provide Unmatched Value To Our Customers.
- ➡ We Believe In Pursuing Excellence At All Levels.
- ➡ Towards This, We Continuously Evolve Product And Process Efficiencies By Implementing Practices That Align With Highest Standards, Nationally And Globally.

THE KIRTAN PRECISION EXPERIENCE

Our Team Is Our Driving Force. We Bring Together Best In Trade Talents With Experience In Varied Fields Like Heat Treatment, Zinc Plating, Zinc Galvanizing, Heavy Engineering, Material Technology And Material Sourcing.

We Are Guided By Industry Experts Who Have Led Various Top Forging & Casting Organization.

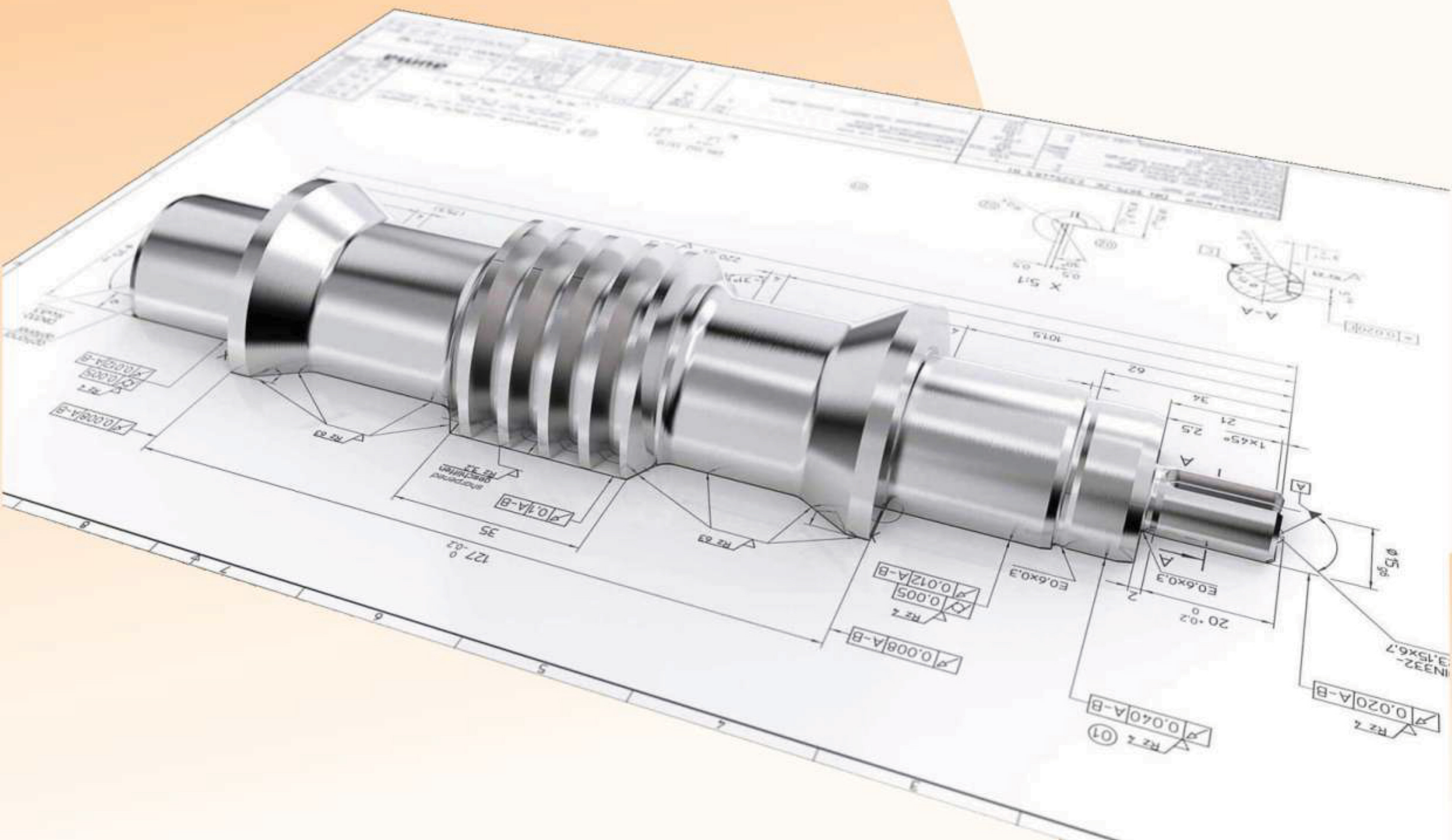

▷ KEY INFRASTRUCTURE AT KIRTAN PRECISION INCLUDLD



BAR CUTTING FACILITY

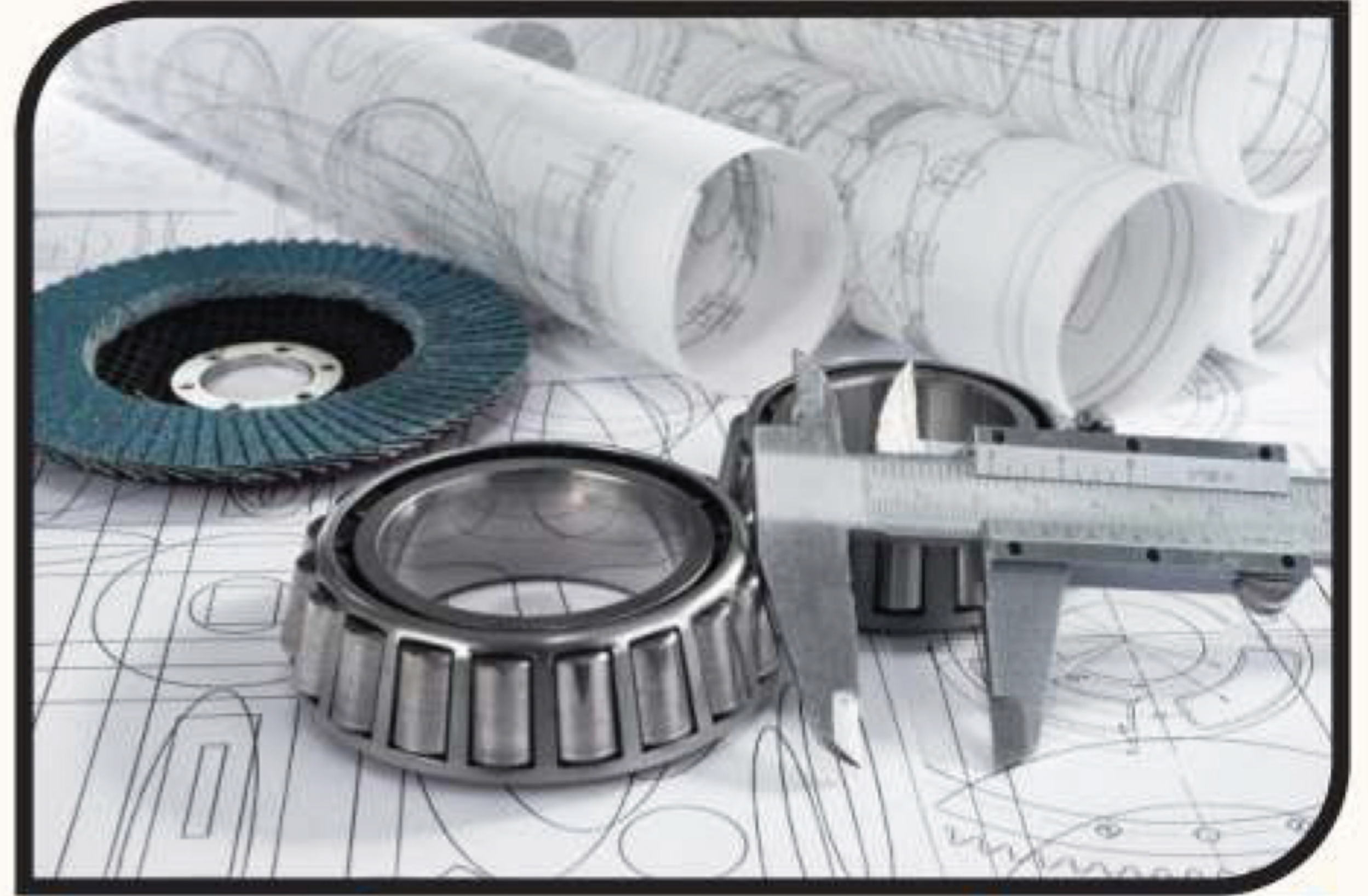

MEASUREMENT & LAR FACILITY



ZINC PLATING ZINC GALVANING (OUTSOURCING)



FORGING & CASTING DESING DEVELOPMENT



SHOT BLASTING



CNC / VMC



OUR PRODUCTS





OUR PRODUCTS

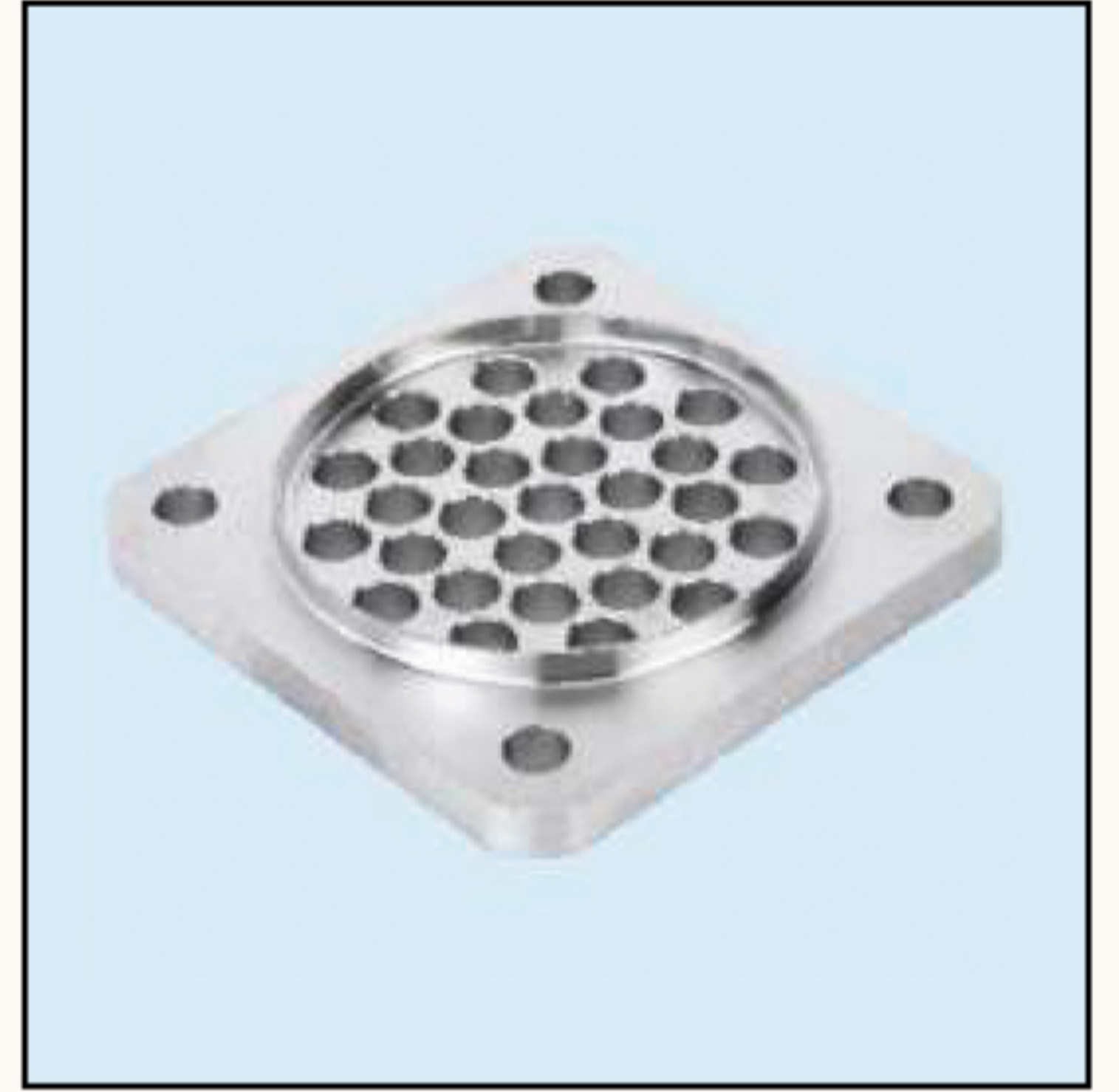
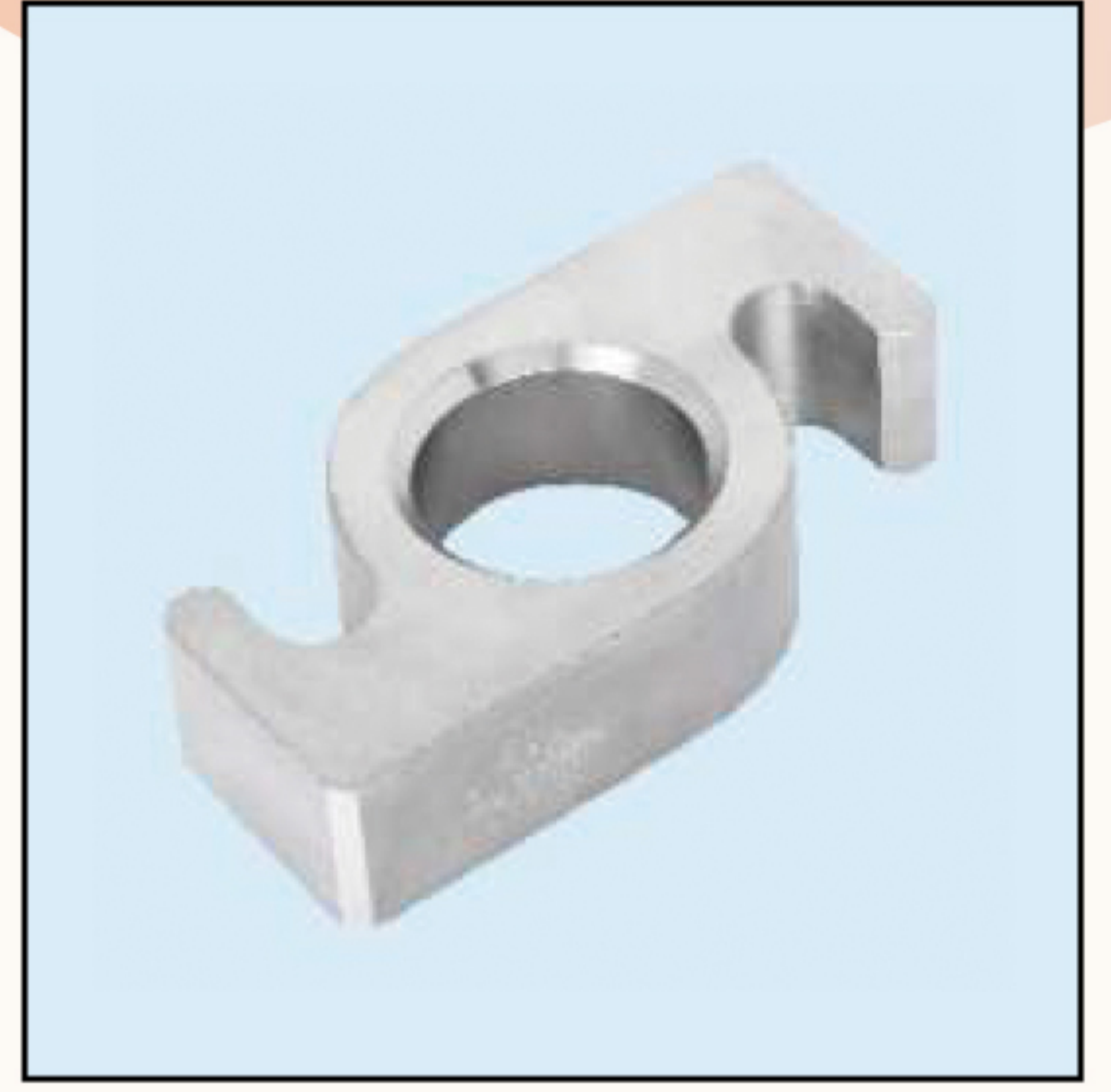



OUR CAPABILITIES

Weight Range : 0.1 kg to 50 kgs

Round Forging : ring Outer Dia. Up to 400 mm & 100.00 mm Thickness

Profile job Forging : 0.1kg to 30.0 kgs

Material Handle Steel, Alloy Steel & Stainless Steel

Manufacturing Facilities

Machine Shop capital Engineering

CNC & VMC M/C : 13 m/c's.

Lathe Machines: 2 m/c's.

Milling Machines: 1 m/c's.

Dot Pin Marking Machines

Ultrasonic Cleaning Machine=100kg/Hrs

Additional Process Offered

Phosphating

Sp. Passivation

Hot Deep Galvanizing

Blackening

Sp. Painting

CED Coating

Zinc-Ni Plating

Testing & Inspection

CMM (Coordinate Measuring Machine)

Magnetic Particles Testing Machine

Ultrasonic test for Crack Detection (Out Source)

Surface Roughness Testing

Hardness Testing (Rockwell & Brinell)

Dial Gauges, Micrometers & Vernier etc.

Ultrasoni Cleaning Machine

FORGING PRODUCTION AREA



**HUTA
ZYGMUNT
3 TON MPM**

**HUTA
ZYGMUNT
1 TON MPM**





HEAT TREATMENT (EXTERNAL)

STRATEGIC TIE-UP TO CARRY OUT HEAT TREATMENT WITH APPROVED SUPPLIER (SHAKTI HEAT TREATERS)



TEMPERING FURNACE



HEATING FURNACE



⇒ **A FULLY AUTOMATED SCADA FURNACES FOR HEAT TREATMENT PROCESS CARRIED OUT...**

- QUENCHING & TEMPERING
- ISO-THERMAL ANNEALING
- NORMALIZING
- SOLUTION ANNEALING
- CARBURIZING
- CARBO NITRIDING
- INDUCTION HARDENING

⇒ **BENEFITS**

- A BETTER MACHINABILITY DUE TO CONSISTENT HARDNESS
- LOWER TOOL CONSUMPTION
- LOWER HARDNESS VARIATION
- AND MANY MORE...



**PLOT NUMBER -18, SUVIDHA
INDUSTRIAL AREA6 BEHIND UMIYA -3,
NATIONAL HIGHWAY,RIBDA RAJKOT,
GUJARAT,360311**



**+91 88662 72793
+91 97272 87884**



**info@kirtanprecision.com
marketing@kirtanprecision.com
tarun@kirtanprecision.com**



www.kirtanprecision.com

